

HP Archive

This vintage Hewlett Packard document was preserved
and distributed by

[www. hparchive.com](http://www.hparchive.com)

Please visit us on the web !

On-line curator: Glenn Robb

This document is for FREE distribution only!

RETURN TO
ELEC. LAB.
IBM CORP.
ENDICOTT, N. Y.

INSTRUCTION AND OPERATING MANUAL
FOR

MODEL 200C

AUDIO OSCILLATOR

Serial 50,000 and Above

Serial # 52442

HEWLETT-PACKARD COMPANY
395 PAGE MILL ROAD, PALO ALTO, CALIFORNIA, U.S.A.

General Description

The Model 200C Audio Oscillator is a general purpose oscillator which uses the resistance-tuned circuit to generate alternating current voltages from 20 to 200,000 cycles/sec.

This audio oscillator provides a source of voltage for amplifier testing, audio response of transmitters, loud speaker resonance tests, a voltage source for bridge measurements and equipment operating in the supersonic range.

Parts Substitution

Difficulties in procuring some of the parts used in this instrument may cause the electrical or physical values to deviate from those shown in this instruction manual. These substitutions have been made so as not to impair the performance of this instrument. Whenever replacement of any of these parts is necessary, either the substitute value or the original value may be used.

INSTRUCTIONS
MODEL 200C
AUDIO OSCILLATOR

Specifications

Frequency Rating --

Frequency Range - 20 to 200,000 cycles/sec.

Frequency Dial Calibration - 20 to 200

Range -

x1 20 - 200 cycles/sec.

x10 200 - 2000 cycles/sec.

x100 2000 - 20,000 cycles/sec.

x1000 20,000 - 200,000 cycles/sec.

Calibration Accuracy - $\pm 2\%$

Frequency Response - ± 1 db 20 - 150,000 cycles/sec.

Reference - 1000 cycles/sec.

10 volts, 1000 ohms resistive load

Frequency Stability - $\pm 2\%$ or .2 cycles/sec. (whichever is greater)

under normal temperature conditions, including
initial warm-up.

$\pm 10\%$ power line voltage variations change the
frequency less than $\pm .2\%$ at 1000 cycles/sec.

Power Output --

Power Output - 100 milliwatts into rated load (10 volts across a 1000
ohms load)

Distortion - Less than 1% of rated output from 20 to 100,000 cycles/sec.

Hum - Less than .1% of rated output

Load Impedance - 1000 ohms (resistive)

Approximate Internal Impedance - 30 ohms from 100 to 100,000
cycles/sec. One side of output grounded.

Power Supply Rating --

Voltage - 115 volts

Frequency - 50 to 60 cycles/sec.

Wattage - 60 watts

Overall Dimensions --

Cabinet Model - 15-1/4" long x 7-1/4" high x 10-5/8" deep
Rack Model - 19" long x 7" high x 10-3/4" deep
Panel - 19" long x 7" high
Depth behind panel - 9-1/4"

Weight --

Cabinet Model - 23 pounds
Rack Model - 24 pounds

Operating Instructions

Inspection --

This instrument has been thoroughly tested and inspected before being shipped and is ready for use when received.

After the instrument is unpacked, the cover and bottom plate should be removed (see Maintenance section) so that the instrument may be carefully inspected for damage received in transit. While the cover is off the tubes should be checked to see that they are firmly seated in their sockets. If any shipping damage is found, follow the procedure outlined in the "Claim for Damage in Shipment" page at the back of this instruction book.

Controls and Terminals --

AC Power - This toggle switch, which is located in the lower left corner of the control panel, controls the power supplied to the instrument from the power line. When the switch is in the on position the red indicator will glow.

Fuse - The fuseholder, located on the underside of the chassis next to the power cable, contains a one ampere cartridge fuse.

RANGE - This rotary switch inserts various range resistors in the frequency determining circuit of the oscillator. The position of this switch indicates the multiplying factor for the frequency dial calibration.

Frequency Dial - The frequency dial is calibrated directly in cycles per second for the lowest frequency range.

AMPL. - This variable resistor controls the amplitude of the oscillator voltage admitted to the amplifier and therefore the output voltage of the instrument. This control is calibrated from "0" to "100" in arbitrary units.

Power Cable - The power cable consists of three conductors. Two of these conductors carry power to the instrument while the third conductor (green wire) is connected to the instrument chassis. The third wire projects from the cable near the plug end of the cable and may be connected to a ground when it is desirable to have a grounded chassis.

Operation --

Plug the power cable of the Model 200C into a nominal 115 volts, 50/60 cycles power source and turn on the AC power switch. The instrument will begin to operate as soon as the tubes have heated, but for maximum accuracy a warm-up period of about 30 minutes is necessary.

Set the frequency dial and RANGE switch so that their indications, when multiplied together, equals the desired frequency. For example, if it is desired to select an output frequency of 800 cycles per second, set the frequency dial to "80" and the RANGE switch to "x10".

Connect the oscillator output binding posts to the equipment being driven and adjust the AMPL. control for the desired output voltage.

Although the rated load for the Model 200C is 1000 ohms (resistive), higher or lower impedance loads may be used without damage to the instrument. A higher impedance load will result in less power output and a lower impedance load will increase the percentage of distortion in the output voltage.

As the output voltage of the audio oscillator is reduced the percentage of hum voltage will increase. At the lower levels this hum voltage becomes quite large, relative to the sine wave output voltage. This undesirable condition can be remedied by operating the audio oscillator at or slightly below rated output and inserting a suitable attenuator between the oscillator and the equipment being driven by the oscillator. The voltage divider circuit shown below is satisfactory for most applications.

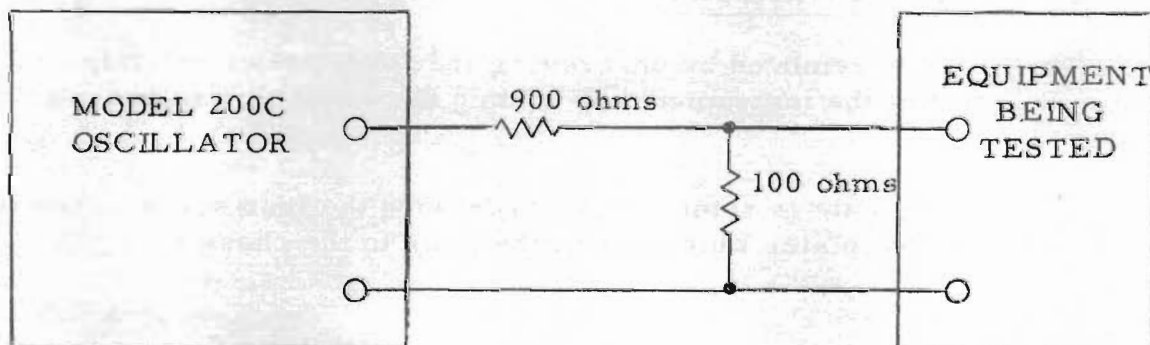

Other values of resistance may be used to obtain different voltage divisions. In all cases, the sum of the divider resistors should equal the rated load.

200C 3/6/50 Serial 50, 000 to

Circuit Description --

The Model 200C Audio Oscillator consists of an oscillator section, an amplifier section and a power supply.

The oscillator section (tubes V1 and V2) is a resistance-tuned type circuit. Basically, this oscillator is a two-stage resistance-coupled amplifier which is caused to oscillate by the use of a positive feedback network. This network is a frequency-selective resistance-capacity combination which controls the frequency of oscillation. By using a variable tuning condenser for the capacity of the network, it is possible to tune the oscillator over a wide 10:1 range; and by using a switching arrangement to select different values of resistance for the network, several ranges are given to the oscillator.

Negative feedback is used in the oscillator section in order to minimize distortion and to obtain a very high order of stability. The amount of negative feedback is determined by a resistance network, one element of which is non-linear (the 3-watt lamp in the cathode of V1). This element controls the amount of feedback in accordance with the amplitude of oscillation and consequently maintains the amplitude of oscillation substantially constant over a wide frequency range. The negative feedback also keeps the operation of the system on the linear portion of the tube characteristics. It is notable that the lamp has sufficient thermal inertia so that it operates well even at low frequencies.

Following the oscillator is the output amplifier section which includes tubes V3 and V4. Negative feedback is used in this amplifier in order to minimize distortion and to provide a good frequency response.

The power supply section includes a conventional full-wave rectifier with a low-pass pi filter for removing the ac components from the rectifier wave.

Maintenance

Cover and Bottom Plate Removal --

The cover is removed by unscrewing the four screws which fasten the cover to the back of the instrument and sliding the cover toward the rear of the instrument.

The bottom plate is removed by unscrewing the four screws, one in each corner of the bottom plate, which fasten the plate to the chassis.

Tube Replacement --

When replacing any of the tubes except the power rectifier, it is desirable to measure the distortion in the output if maximum performance from the instrument is desired, because a poor tube can cause excessive distortion without

seemingly affecting the operation. The distortion should be less than 1% of the rated output with rated load. Distortion may also be caused by leaking coupling capacitors and open by-pass capacitors.

Replacement of Lamp R19 --

The 3-watt lamp R19 is operated at very low level and should have an almost infinite life. Therefore, the lamp should not be changed indiscriminately. However, should the lamp require changing, it is necessary to check the ac voltage from the junction of R28 and C8 to ground with the new lamp in the circuit. As measured with a high-impedance ac vacuum tube voltmeter, this voltage should be within the range of approximately 20-22 volts when the Model 200C is tuned to 400 cps. If the voltage is not within this range, it may be corrected by adjusting R18.

If the voltage cannot be brought within the range from 20-22 watts by means of R18, the new lamp should be rejected in favor of another.

Intermittent Output --

"Jumpy" or intermittent output accompanied by flashing of the 3-watt oscillator lamp (R19) is a reliable indication of a short in trimmer condenser C1 or in the first two sections of the main tuning condenser. If these symptoms occur, search out and clear the short with a weak air jet or other means. Do not bend the condenser plates because bending condenser plates will destroy the frequency calibration.

A short in the back two sections of the main tuning condenser or in trimmer C3 will prevent the circuit from oscillating. Any such short should be cleared as explained above.

Distortion --

Distortion may be caused by defective tubes, electrical leakage in the coupling capacitors, defective electrolytic capacitors, low DC supply voltage, or excessive output voltage from the oscillator section.

Dial Coupler --

An insulated coupler connects the main tuning dial to the shaft of the main tuning condenser. If this coupler should become loosened, rotate the condenser completely clockwise. To do this it will be necessary to loosen the collar of the stop on the rear of the panel bearing. When the condenser is completely closed, set the main tuning dial so that the dot to the left of "20" on the main tuning dial is exactly under the hairline. Tighten the coupler with the tuning dial and tuning condenser in these relative positions. Then tighten the collar of the stop so that the tuning condenser rotor cannot strike the frame or stator at either end of its arc.

After the coupler has been tightened and the dust cover replaced, it is desirable to check the calibration of the instrument.

Frequency Calibration --

If a change occurs in the frequency calibration of the instrument after a long period of use, the cause of this change probably lies in the ageing of the resistors in the frequency-determining network. These resistors have extremely good stability, however, and the frequency calibration will remain accurate for a very long period of time.

Each of the frequency-determining resistors consists of a precision one-watt resistor in series with a one-half watt resistor. The latter is selected to give the instrument a very accurate frequency calibration. Therefore, adjusting the frequency calibration requires that the value of these small resistors be changed as necessary to obtain proper calibration.

An oscilloscope, an ac vacuum tube voltmeter, and a secondary frequency standard are needed to adjust the calibration of the Model 200C. The secondary standard should have sinusoidal output and should provide frequencies of at least 1 kc and 10 kc. Before recalibrating, allow the Model 200C to heat for thirty minutes or more. Then connect the Model 200C to the vertical deflecting-plate input of the oscilloscope and the secondary frequency standard to the horizontal deflecting-plate input.

Next, check the calibration of the Model 200C by means of Lissajous figures on the oscilloscope, determining whether the frequencies generated by the Model 200C are in general higher or lower than the dial calibration. When making this check, it is necessary that the dust cover be tightly on the instrument as the frequency calibration will change when the dust cover is loose or off the instrument.

If the instrument is in need of recalibration, the dial calibration will show a definite trend of error--either higher or lower than the true output frequency for each range. The various ranges of the instrument do not necessarily change in the same "direction".

If the x1 range requires readjusting, change the small resistors R1 and R16. If the output frequency is higher than the dial calibration, increase the value of the small resistors; if the output frequency is lower than the dial calibration, decrease the value of the small resistor. A change of about 100,000 ohms will change the calibration about 1/2%. Do not change the value of R1 more than 100,000 ohms without making a corresponding change in R16, because it is necessary to keep the values of each set of range resistors as equal as possible. Unbalance in the resistors will tend to cause the oscillator to be unstable. After each change it is necessary to replace the dust cover securely before checking the output frequency.

The same procedure should be used if it is necessary to adjust the calibration of the other ranges. On the x10 range a change greater than 10,000 ohms should not be made in R2 without also changing R15. On the x100 range a change greater than 1000 ohms should not be made in R3 without changing R14. On the x1000 range a change greater than 100 ohms should not be made in R4 without also changing R12.

It is important that the dust cover be tightly in place after each adjustment, because the frequency calibration is affected by the position of the dust cover.

If any considerable amount of change in the resistors is necessary, it may be desirable to replace the entire range switch assembly. These assemblies are available from the Hewlett-Packard Company.

The vacuum tube voltmeter should be used to check the output from the instrument after the recalibration has been completed. Set the main frequency dial of the Model 200C to "100" and the AMPL. control to about "80" or more. Connect the VTVM to the output terminals and measure the output of each range. If the range switch resistors have been properly adjusted, the difference between the output of the ranges with the dial set at "100" should be within 1 db (approximately 12%), preferably less. If the difference in output is greater than 1 db, the usual cause is that the frequency determining resistors for the range in question are not properly balanced.

Trimmer Capacitors --

Two trimmer capacitors are provided for the main tuning condenser. These trimmers are adjusted at the factory and do not require further adjustment for the life of the equipment. If the trimmers inadvertently become misadjusted, directions for resetting should be requested of the Hewlett-Packard Company.

Trouble Shooting --

The following is a listing of possible symptoms, causes, and remedies.

| <u>Symptoms</u> | <u>Causes</u> | <u>Remedies</u> |
|---|--|--|
| Instrument inoperative (Indicator lamp won't light, no audio output) | Blown fuse | Clear short circuit and replace fuse |
| Instrument inoperative (Indicator lamp lights, no audio output) | Defective tube; check the 5Y3GT tube first | Replace tube (see "Tube Replacement" in Maintenance section) |

Short circuit in DC power circuit capacitor

Replace capacitor

RETURN TO

ELEC. LAB.

IBM CORP.

ENDICOTT, N. Y.

Symptoms

Instrument inoperative
(Indicator lamp lights,
no audio output)

Intermittent Output

Causes

Short circuit in
C2 (two rear
sections or C3)

Short circuit in
C2 (two front sec-
tions) or C1

Capacitors C8 or
C9 intermittently
open

Remedies

Clear the short cir-
cuit as outlined in the
"Intermittent Output"
paragraph in the Main-
tenance section.

Clear the short cir-
cuit as outlined in
the "Intermittent
Output" paragraph in
the Maintenance sec-
tion.

Replace capacitor

INSTRUCTIONS FOR RECTIFIER TUBE REPLACEMENT

These instructions apply to any Hewlett-Packard instrument in which a 5V4 tube is mounted in the power rectifier tube socket. When it is necessary to replace the rectifier tube, a 5Y3GT tube may be used as a replacement if the following instructions are followed.

INSTRUMENTS WITH DC VOLTAGE REGULATOR CIRCUIT -

The 5V4 tube may be replaced by a 5Y3GT tube without any circuit changes. After the 5Y3GT tube has been installed, the regulated voltage should be measured to see if it agrees with the voltage shown on the schematic wiring diagram in the instruction book. If the regulated voltage is incorrect, it may be corrected by following the instructions in the instruction book.

INSTRUMENTS WITHOUT DC VOLTAGE REGULATOR CIRCUIT -

The 5V4 tube may be replaced by a 5Y3GT tube providing the resistor, in series with the DC output of the rectifier, is removed. This resistor does not appear in the schematic wiring diagram in the instruction book. The following instruments use a 500 ohms series resistor: Models 200C, 200D, 202D, 210A, 300BCD, and the 400A.

RET. U
ELE. 3.
IBM CORP.
ENDICOTT, N. Y.

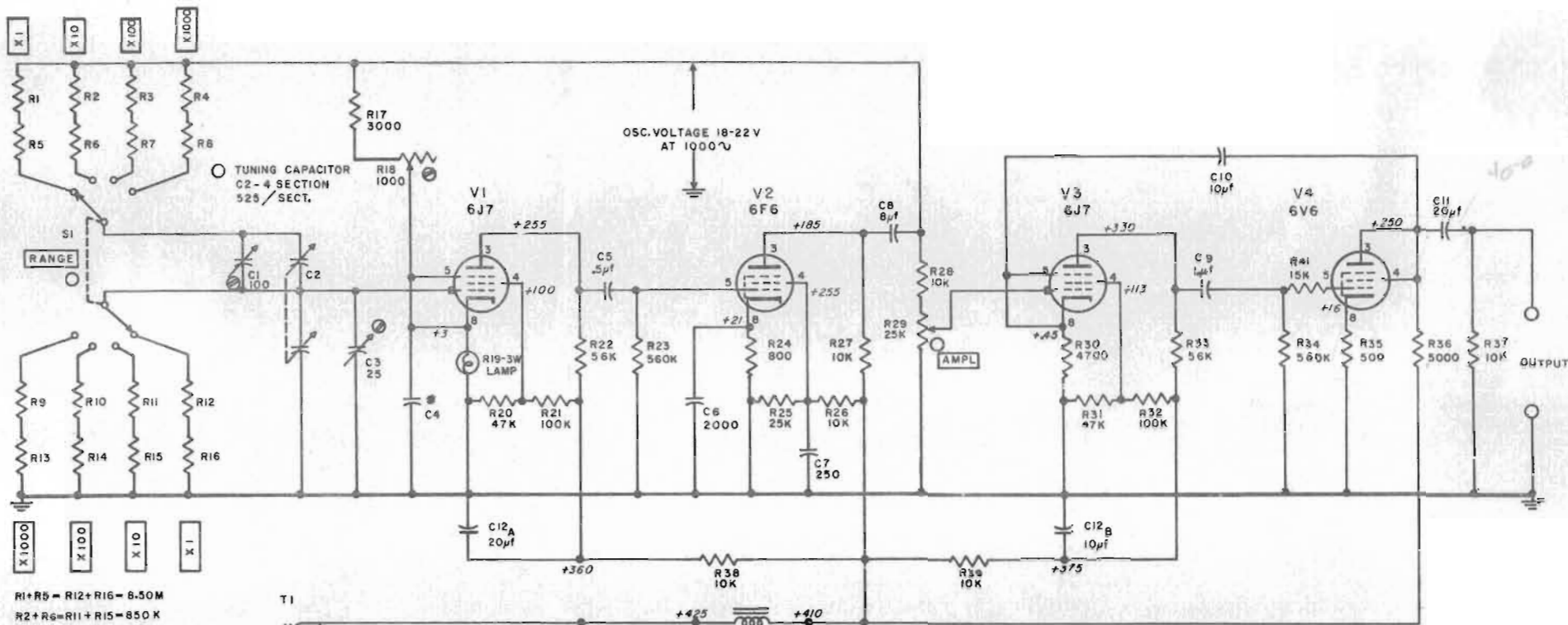

$R1+R5 = R2+R6 = 6.50M$
 $R2+R6 = R11+R15 = 850K$
 $R3+R7 = R10+R14 = 84.6K$
 $R4+R8 = 6.18K$
 $R9+R13 = 6.38K$

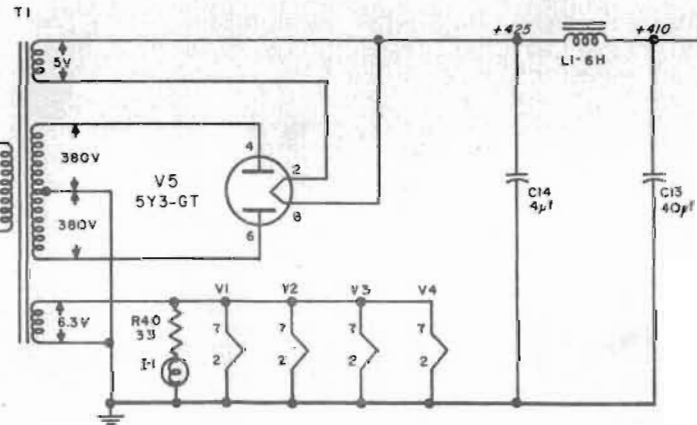
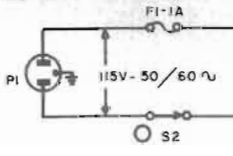

NOTES:
CONDITIONS OF DC VOLTAGE MEASUREMENT
 1. 115V, 50-60 CYCLE POWER SUPPLY
 2. MEASUREMENT TAKEN BETWEEN THE INDICATED POINTS AND CHASSIS WITH A VOLTMETER OF 122 MEGOHMS INPUT RESISTANCE
 3. SET R28 AT ZERO AND S1 AT X10
 ○ PANEL CONTROL
 ⊕ SCREWDRIVER ADJ.
 ⊕ CHASSIS
 CAPACITY IN μUF UNLESS OTHERWISE NOTED
 K = 1000 OHMS
 M = 1 MEGOHM
 * ELECTRICAL VALUE ADJUSTED BY THE FACTORY, AVERAGE VALUE SHOWN. PART MAY BE OMITTED.

SCHEMATIC DIAGRAM OF MODEL 200C AUDIO OSCILLATOR
SERIAL 5000 TO

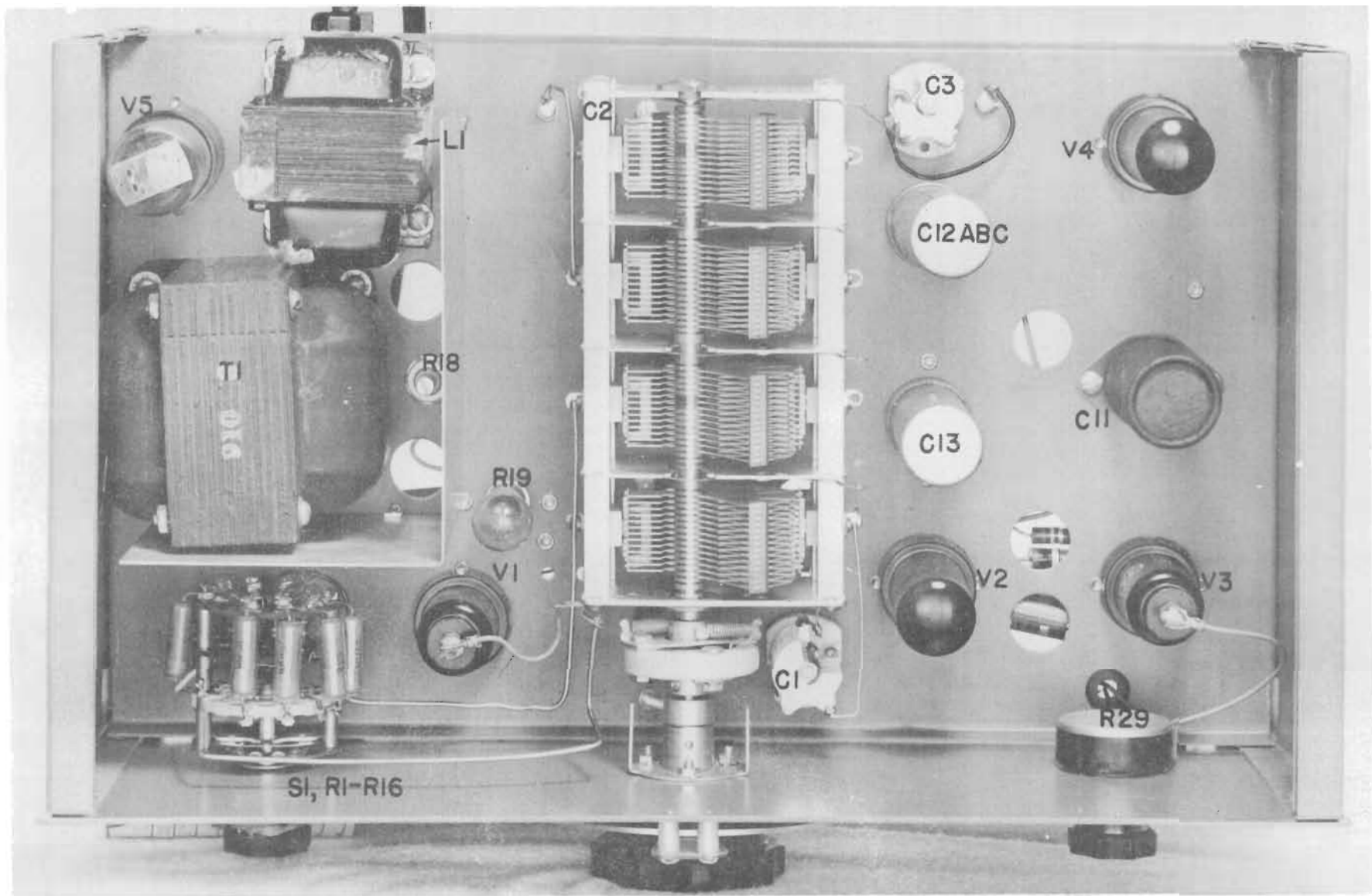

Model 200C Top View
Cover Removed

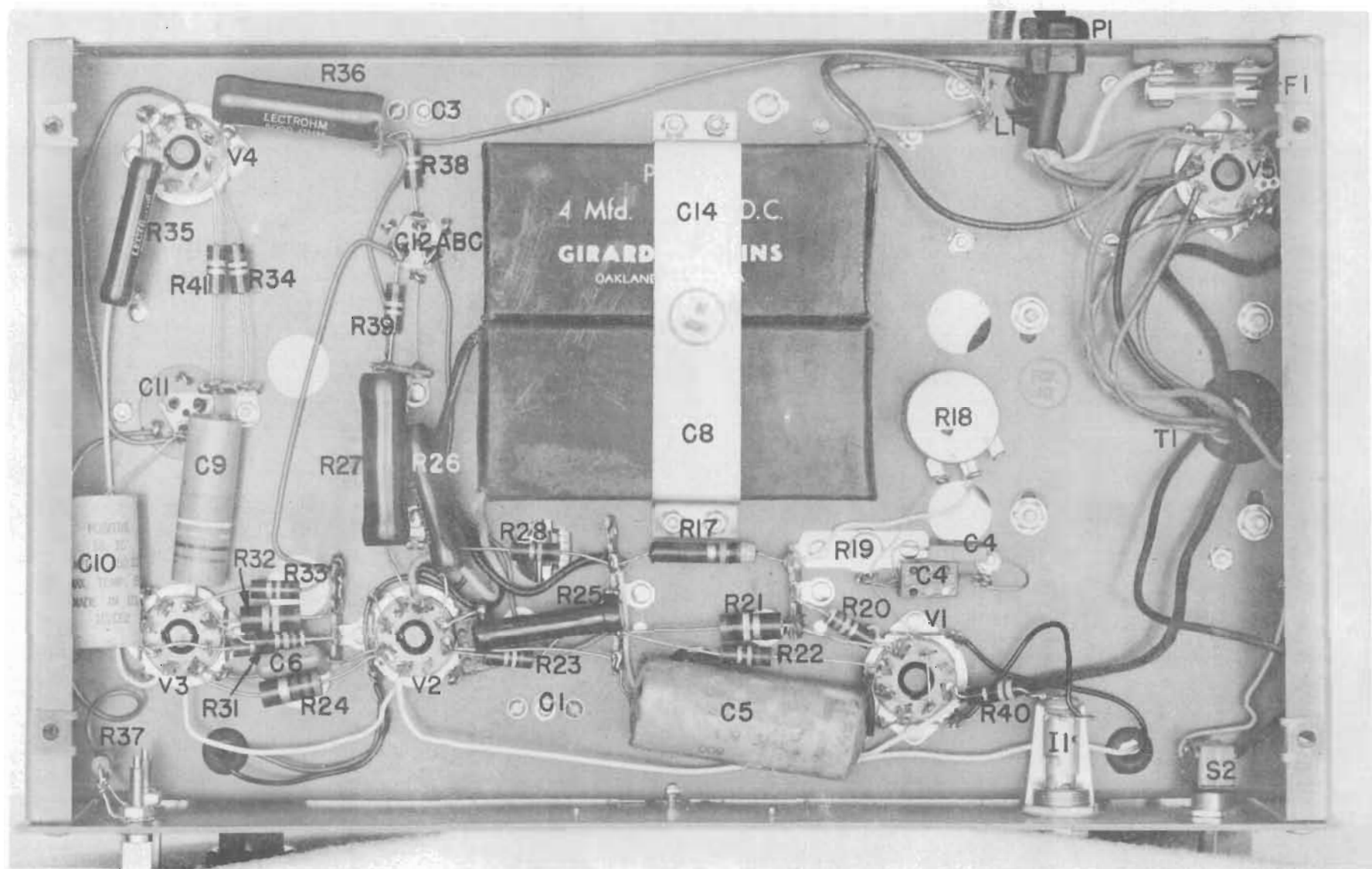

Model 200C Bottom View
Bottom Plate Removed

TABLE OF REPLACEABLE PARTS

| Circuit Ref. | Description | -hp- Stock No. | Mfr. * & Mfrs. Designation |
|--------------|--|----------------|----------------------------|
| C1 | Capacitor: variable, air, 100 μ f | 12-11 | AA, A-103L |
| C2 | Capacitor: variable, air, 530 μ f per sect. | 12-5 | HP |
| C3 | Capacitor: variable, air, 25 μ f | 12-9 | AA, A-25L |
| C4 | Capacitor: Factory Adjustment | | |
| C5 | Capacitor: fixed, paper, .5 μ f, 600 vdcw | 16-5 | A Type 684 |
| C6 | Capacitor: fixed, mica, 2000 μ f, 500 vdcw | 14-13 | V Type W |
| C7 | Capacitor: fixed, mica, 250 μ f, 500 vdcw | 14-250 | V Type OXM |
| C8 | Capacitor: fixed, paper, 4, 4 μ f, 600 vdcw | 17-44 | P P8-8 |
| C9 | Capacitor: fixed, paper, .1 μ f, 600 vdcw | 16-1 | A Type P688 |
| C10 | Capacitor: fixed, electrolytic, 10 μ f, 450 vdcw | 18-10 | X WB 72 |
| C11 | Capacitor: fixed, electrolytic, 20 μ f, 450 vdcw | 18-20 | X FPS-144 |
| C12 ab | Capacitor: fixed, electrolytic, 10, 10, 10 μ f, 450 vdcw | 18-31 | X FPT-389 |
| C13 | Capacitor: fixed, electrolytic, 40 μ f, 450 vdcw | 18-40 | X FPS-146 |
| C14 | Capacitor: fixed, paper, 4 μ f, 800 vdcw | 17-3 | P P8-4 |
| R1-R16 | Part of Range Switch Assembly | | |
| R17 | Resistor: fixed, wirewound, 3000 ohms, \pm 10%, 1W | 26-3000 | R Type BW |

*See "List of Manufacturers Code Letters For Replaceable Parts Table."

-200G 3/6/50 Serial 50,000 to

TABLE OF REPLACEABLE PARTS

| Circuit Ref. | Description | -hp- Stock No. | Mfr. * & Mfrs. Designation |
|--------------|--|----------------|----------------------------|
| R18 | Resistor: variable, wirewound, 1000 ohms, linear taper | 210-5 | G 21-010-355 |
| R19 | Lamp: 3-watt | 211-4 | O |
| R20 | Resistor: fixed, composition, 47,000 ohms, $\pm 10\%$, 1 W | 24-47K | B GB 4731 |
| R21 | Resistor: fixed, composition, 100,000 ohms, $\pm 10\%$, 2 W | 25-100K | B HB 1041 |
| R22 | Resistor: fixed, composition, 56,000 ohms, $\pm 10\%$, 1 W | 24-56K | B GB 5631 |
| R23 | Resistor: fixed, composition, 560,000 ohms, $\pm 10\%$, 1 W | 24-560K | B GB 5641 |
| R24 | Resistor: fixed, composition, 820 ohms, $\pm 10\%$, 2 W | 25-820 | B HB 8211 |
| R25 | Resistor: fixed, wirewound, 25,000 ohms, $\pm 10\%$, 10 W | 26-11 | S Type 1-3/4 |
| R26 | Resistor: fixed, wirewound, 10,000 ohms, $\pm 10\%$, 10 W | 26-10 | S Type 1-3/4E |
| R27 | Resistor: fixed, wirewound, 10,000 ohms, $\pm 10\%$, 20 W | 27-4 | S Type 2R |
| R28 | Resistor: fixed, composition, 10,000 ohms, $\pm 10\%$, 1 W | 24-10K | B GB 1031 |
| R29 | Resistor: fixed, composition, 25,000 ohms, linear taper | 210-54 | B JU 2531 |
| R30 | Resistor: fixed, composition, 4700 ohms, $\pm 10\%$, 1 W | 24-4700 | B GB 4721 |
| R31 | Resistor: fixed, composition, 4700 ohms, $\pm 10\%$, 1 W | 24-47K | B GB 4731 |
| R32 | Resistor: fixed, composition, 100,000 ohms, $\pm 10\%$, 2 W | 25-100K | B HB 1041 |
| R33 | Resistor: fixed, composition, 56,000 ohms, $\pm 10\%$, 1 W | 24-56K | B GB 5631 |

*See "List of Manufacturers Code Letters For Replaceable Parts Table."

TABLE OF REPLACEABLE PARTS

| Circuit Ref. | Description | -hp- Stock No. | Mfr. * & Mfrs. Designation |
|--------------|---|----------------|----------------------------|
| R34 | Resistor: fixed, composition, 560,000 ohms, +10%, 1 W | 24-560K | B GB 5641 |
| R35 | Resistor: fixed, wirewound, 500 ohms, +10%, 10 W | 26-5 | S Type 1-3/4E |
| R36 | Resistor: fixed, wirewound, 5000 ohms, +10%, 20 W | 27-3 | S Type 2R |
| R37 | Resistor: fixed, composition, 10,000 ohms, +10%, 1 W | 24-10K | B GB 1031 |
| R38 | Resistor: fixed, composition, 10,000 ohms, +10%, 1W | 24-10K | B GB 1031 |
| R39 | Resistor: fixed, composition, 10,000 ohms, +10%, 1W | 24-10K | B GB 1031 |
| R40 | Resistor: fixed, composition, 33 ohms, +10%, 1W | 24-33 | B GB 3301 |
| | Binding Post: | 312-3 | HP |
| F1 | Fuse: 1A, 3AG | 211-1 | T, 312001 |
| | Fuseholder: | 312-7 | T, 351011 |
| | Power Cable: | 812-56 | HP |
| | Knob: 3" diam. | 37-14 | HP |
| | Knob: 1-1/2" diam. | 37-11 | HP |
| I1 | Lamp: | 211-47 | O, #47 |
| | Indicator Light: | 312-10 | BB, 807BS |
| L1 | Reactor: 6H @ 125MA, 240 ohms | 911-4 | HP |
| | Coupling Assembly: | M-25B | HP |
| | Panel Bearing Assembly: | M-67 | HP |
| S1 | Switch: Range | C-19W | HP |

*See "List of Manufacturers Code Letters For Replaceable Parts Table."

TABLE OF REPLACEABLE PARTS

| Circuit Ref. | Description | -hp- Stock No. | Mfr. * & Mfrs. Designation |
|--------------|----------------|----------------|----------------------------|
| S2 | Switch: Toggle | 310-11 | D, 20994-HW |
| T1 | Transformer: | 910-3 | HP |
| V1 | Tube: 6J7 | 212-6J7 | ZZ |
| V2 | Tube: 6F6 | 212-6F6 | ZZ |
| V3 | Tube: 6J7 | 212-6J7 | ZZ |
| V4 | Tube: 6V6 | 212-6V6 | ZZ |
| V5 | Tube: 5Y3GT | 212-5Y3GT | ZZ |

*See "List of Manufacturers Code Letters For Replaceable Parts Table."

200C 3/6/50 Serial 50, 000 to

LIST OF MANUFACTURERS CODE LETTERS
FOR REPLACEABLE PARTS TABLE

| <u>Code Letter</u> | <u>Manufacturer</u> |
|--------------------|--|
| A | Aerovox Corp. |
| B | Allen-Bradley Co. |
| C | Amperite Co. |
| D | Arrow, Hart and Hegeman |
| E | Bussman Manufacturing Co. |
| F | Carborundum Co. |
| G | Centralab |
| H | Cinch Manufacturing Co. |
| I | Clarostat Manufacturing Co. |
| J | Cornell Dubilier Electric Co. |
| K | Electrical Reactance Co. |
| L | Erie Resistor Corp. |
| M | Federal Telephone and Radio Corp. |
| N | General Electric Co. |
| O | General Electric Supply Corp. |
| P | Girard-Hopkins |
| HP | Hewlett-Packard |
| Q | Industrial Products Co. |
| R | International Resistance Co. |
| S | Lectrohm, Inc. |
| T | Littelfuse, Inc. |
| U | Maguire Industries, Inc. |
| V | Micamold Radio Corp. |
| W | Oak Mfg. Co. |
| X | P. R. Mallory Co., Inc. |
| Y | Radio Corp. of America |
| Z | Sangamo Electric Co. |
| AA | Sarkes Tarzian |
| BB | Signal Indicator Co. |
| CC | Sprague Electric Co. |
| DD | Stackpole Carbon Co. |
| EE | Sylvania Electric Products, Inc. |
| FF | Western Electric Co. |
| GG | Wilkor Products, Inc. |
| HH | Amphenol |
| II | Dial Light Co. of America |
| JJ | Leecraft Manufacturing Co. |
| ZZ | Any tube having RMA standard characteristics |

CLAIM FOR DAMAGE IN SHIPMENT

The instrument should be tested as soon as it is received. If it fails to operate properly, or is damaged in any way, a claim should be filed with the carrier. A full report of the damage should be obtained by the claim agent, and this report should be forwarded to us. We will then advise you of the disposition to be made of the equipment and arrange for repair or replacement. Include model number, type number and serial number when referring to this instrument for any reason.

WARRANTY

Hewlett-Packard Company warrants each instrument manufactured by them to be free from defects in material and workmanship. Our liability under this warranty is limited to servicing or adjusting any instrument returned to the factory for that purpose and to replace any defective parts thereof (except tubes, fuses and batteries). This warranty is effective for one year after delivery to the original purchaser when the instrument is returned, transportation charges prepaid by the original purchaser, and which upon our examination is disclosed to our satisfaction to be defective. If the fault has been caused by misuse or abnormal conditions of operation, repairs will be billed at cost. In this case, an estimate will be submitted before the work is started.

If any fault develops, the following steps should be taken:

1. Notify us, giving full details of the difficulty, and include the model number, type number and serial number. On receipt of this information, we will give you service instructions or shipping data.
2. On receipt of shipping instructions, forward the instrument prepaid, and repairs will be made at the factory. If requested, an estimate of the charges will be made before the work begins provided the instrument is not covered by the warranty.

SHIPPING

All shipments of Hewlett-Packard instruments should be made via Railway Express. The instruments should be packed in a wooden box and surrounded by two to three inches of excelsior or similar shock-absorbing material.

DO NOT HESITATE TO CALL ON US

HEWLETT-PACKARD COMPANY

Laboratory Instruments for Speed and Accuracy

395 PAGE MILL ROAD

PALO ALTO, CALIF.

